

Neato Botvac™

Let it run. Your work is done.



neato™

Neato Botvac™ User Manual

Welcome!

Thank you for purchasing a Neato Botvac™ and welcome to the world of robots helping humans.

If you can't wait to get your robot working for you, just skip ahead to the "Getting Started Guide" that is included with your Neato Botvac. It has the essentials to get you up and running right away.

If you want to become well-acquainted with your new robot friend, you can spend some time with this User Manual and learn all about your new robot. In fact, you may even want to start thinking about what you will name your new helper! There are a few key steps that will ensure a successful partnership - things like preparing a room for a robot cleaning, getting the most from your battery, and how to regularly maintain your robot to get the longest life. For more information on these and other issues, and to stay up-to-date with the most current information, you can always visit us at **www.neatorobotics.com** and click on **Support**. There you will find answers to frequently asked questions, the latest tips and tricks for optimal robot performance, and current information about software updates.

Let's stay in touch. One of the best ways do this is by registering your robot - just go to **www.neatorobotics.com**, click on **MyNeato**, and follow the registration process.

Congratulations on your new household helper, and get ready to cross a few chores off of your "to do" list.

Make Life Neater™,
Your friends at Neato Robotics

P.S. Don't forget to register your Neato Robot. Just visit **www.neatorobotics.com** and click on **MyNeato**.

TABLE OF CONTENTS

- Safety Information** 4
- 1. How Botvac™ Works** 9
- 2. Neato Botvac™ Anatomy** 11
- 3. Controls** 14
- 4. Setting Language** 16
- 5. Setting Clock** 17
- 6. Cleaning** 19
- 7. Boundary Markers** 23
- 8. Scheduling** 25
- 9. Maintenance** 28
- 10. Batteries and Charging** 32
- 11. Troubleshooting** 37
- 12. Neato Customer Care and Product Registration** 48

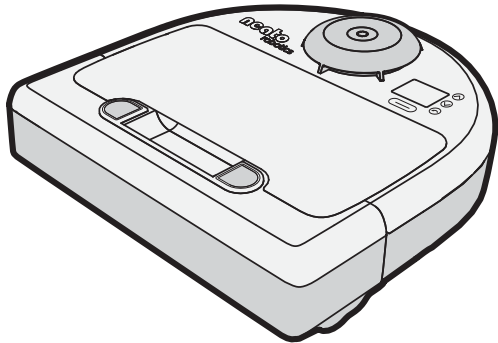

BEFORE GETTING STARTED

- Read all documentation before using your Neato robot for the first time.
- Keep the documentation for your Neato robot for future use.

INTENDED USE



Note!

The appliance is not to be used by children younger than 8. Children 8 and older or persons with reduced physical, sensory or mental capabilities, or lack of experience and knowledge may only use this appliance if they are supervised or have been given instruction about how to use it safely and understand what risks are involved. Children should be supervised to ensure they do not play with the robot or charge base. Children without adult supervision should not perform cleaning and maintenance of the robot or charge base.

HAZARD WARNINGS



Risk of electric shock!

- Always switch the device off before carrying out any cleaning or maintenance work. Disconnect the power plug from the charge base.
- Never pull the power plug out of the socket by the power cord; instead, pull it out by the power plug itself.
- Disconnect the power plug from the socket before opening the charge base.
- Never perform repairs on your device yourself. Repairs to electric devices may only be carried out by Neato customer service.
- Do not insert any pointed objects into the electric contacts.
- Do not change the contacts.
- Never carry the charge base by the power cord.
- Do not continue to operate the robot if the device itself or the power cord is damaged.

- Contact your Neato customer service in the event of damage.
- Do not clean the robot, the charge base or the power cable in water or other liquids.
- Do not use the robot on damp ground or in places in which it can get into contact with liquids or be immersed in water.
- Do not use the robot in humid environments, such as wet bathrooms.
- Do not use the robot in hazardous areas such open fireplaces, running showers or swimming pools.
- Make sure that you do not damage, bend or twist the power cord. Do not place any heavy objects on top of the cord. This could damage the power cord and cause a fire or electrical shock.
- Drooping or bare cables, curtains, tablecloths or cords in the working area of the robot are to be secured in order to avoid damage to the it or cause an electrical shock.
- Make sure no fragile, light, loose or movable objects are within range of the robot.



Fire hazard!

- Do not vacuum up any hot ashes or lit cigarettes with the robot.
- The batteries must never be placed in an open fire and/or heated by an external heat source.
- Never use the robot in rooms with burning candles or desk lamps on the floor.



Explosion hazard!

- Do not vacuum up any explosive or easily flammable substances.

 **Risk of injury!**

- Never run the robot over any part of the body. Do not vacuum close to children or pets; keep body parts away from the spinning brush.

 **Risk of pinching!**

- Keep away from moving parts.

 **Note! Risk of damage from improper use!**

- Use Neato Genuine Accessory parts only.
- Use the charge base exclusively with the alternating current voltage stated on the type plate and on a connection that has been properly installed by an expert.
- Do not use the robot if the charge base, the power cord or the robot are faulty or damaged, or if the robot has not been completely assembled.
- If the power cord or charge base is faulty, it must be replaced with a Neato Genuine Accessory to avoid hazards.
- Never try to repair the robot by yourself.
- This robot is intended for indoor use only.
- This robot is intended for the cleaning of floors only.
- Make sure that children do not play with the robot.
- Keep children and pets away from the robot; do not let them stand or sit on it.
- Do not vacuum up any cleaning powders with the robot.
- Very fine sand, limestone, cement dust or similar particulates will block the pores of the filter and reduce performance.
- Never use the robot without the filter. This will damage the motor and shorten the life of the robot.
- To charge the robot, only use the power cord and charge base included in the box.

- Do not cover the infrared window of the charge base with stickers or other objects that can block the window.
- Do not block the sensors on the robot. Otherwise it will no longer be able to orientate itself or communicate with the charge base.
- The robot can be used on most carpets with a fiber length of up to 0.7in (20mm). It may move slower on carpet than hard wood.
- Do not use 3rd party batteries with the robot. Only use Genuine Neato Accessory batteries.
- Do not use the robot on top of worktops or glass-ceramic stove tops.
- Make sure that no fragile, light or loose objects are within range of the robot.
- If the drop sensors are dirty, the robot may fall down stairs or off ledges. This can cause serious damage to the device. Please clean the drop sensors regularly
- If there are steps in the working area of the robot, the enclosed boundary markers can be applied to the top stair. The minimum distance to the edge of the step should be approximately 0.75in (2cm) on hardwood or thin carpet. On thick carpet the minimum distance to the edge of the step should be approximately 6in (15cm). This is an extra safety measure to prevent the robot from falling off a ledge or stairs.

! Laser Distance Sensor (LDS)

The laser distance sensor contains a rotating class 1 laser according to DIN EN 60825-1. In general, the following codes of practice apply for lasers:

- Switch the robot off before refit or repair.
- Do not direct the laser beam at people.
- Do not look into the direct or reflected beam of the laser.
- It is not permitted to carry out manipulations (alterations) or attempt repairs on the device and especially on the LDS.

! Electromagnetic fields

- The robot meets all standards regarding electromagnetic fields (EMF).
- According to current scientific findings, the robot is safe to use provided that it is handled correctly and in accordance with the instructions in the user manual.
- The device complies with the safety requirements of the country in which it was sold by a Neato Authorized Distributor.
- By using the device in another country, compliance with local safety standards cannot be guaranteed. Neato therefore rejects any resulting safety risks for the user.

HOW BOTVAC WORKS

1

Your Neato Botvac uses sophisticated mapping software to create a map of your home and plan its cleaning.

The foundation of Neato's robotic technology is its patented Neato Botvision™ – a breakthrough in robotic mapping and navigation. Botvision uses a proprietary laser scanner and proprietary navigation software based on SLAM (Simultaneous Localization and Mapping) – the same technology used by the Google self-driving car. This is a milestone achievement – Neato has brought a laser scanning technology that typically costs thousands of dollars to a consumer product at an affordable price.

Smart mapping – Neato's patented laser distance system continually scans the room, making instant decisions based on input from its external sensors. This enables Botvac to create detailed and accurate maps of its environment and methodically clean in an organized back and forth pattern, leaving the straight carpet vacuum lines.

OTHER ROBOTS

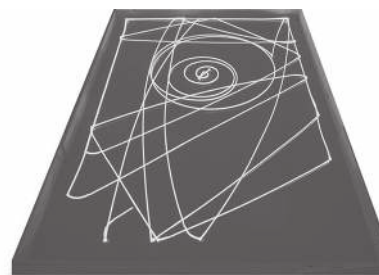

NEATO ROBOTS

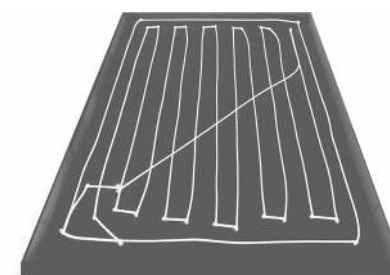

Instead of bumping around like other robot vacuums, Neato Botvac uses patented Neato Botvision to scan and map the room, plan, and methodically clean.

Tip! Give It Power

Charge it when you aren't using it to ensure it is ready to clean and to maintain the batteries.

Tip! Set Cleaning Boundaries

Your Botvac will clean everywhere it can reach. If you want to keep it from a certain area, just put down boundary markers. It will clean up to the boundary markers but will not cross over them. See section on Boundary Markers for more information.

Tip! Keep It Well-Maintained

Because it's down in the dirt all day long, your Botvac can get a little grungy. See section on Maintenance for more information.

IMPORTANT! Risk of damage from improper use

Remove light, fragile or movable objects from the floor. Remove shag carpets from the area that you would like to clean.

IMPORTANT! Keep It Away From Water, Chemicals, or Other Mold Producing Fluids

Do not clean wet messes with your Botvac.
Do not bathe or otherwise submerge your Botvac in water.

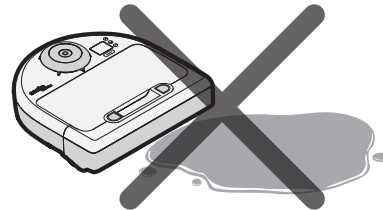

Do not use harsh chemicals on your Botvac, or anything that can permanently stain it.

IMPORTANT! Keep Botvac Away From Hanging Cables and Low To The Ground Tablecloths and Curtains

To keep your Botvac and your home safe, make sure that it cannot get caught on tablecloths, curtains, hanging electric cords, or other cord-like items.

IMPORTANT! Don't Let It Get Cold

Exposing your Botvac to freezing temperatures may cause permanent damage.

IMPORTANT! Don't Use or Store It Outside



Your Botvac is an indoor device and is not intended for outdoor use. Use and store it in the house.

NEATO BOTVAC™ ANATOMY

2

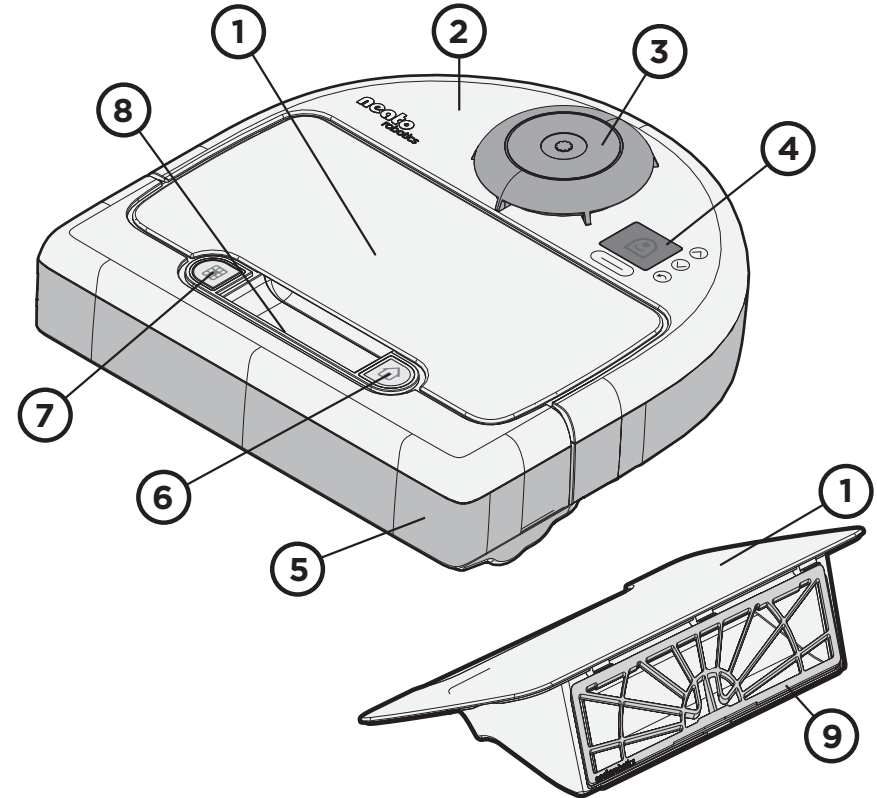
TOP VIEW



- 1 Dirt Bin
- 2 Botvac Top
- 3 Laser Top
- 4 Display Screen
- 5 Bumper
- 6 CLEAN House Button 
- 7 CLEAN Spot Button 
- 8 Handle for Carrying Botvac
- 9 Filter

BOTTOM VIEW

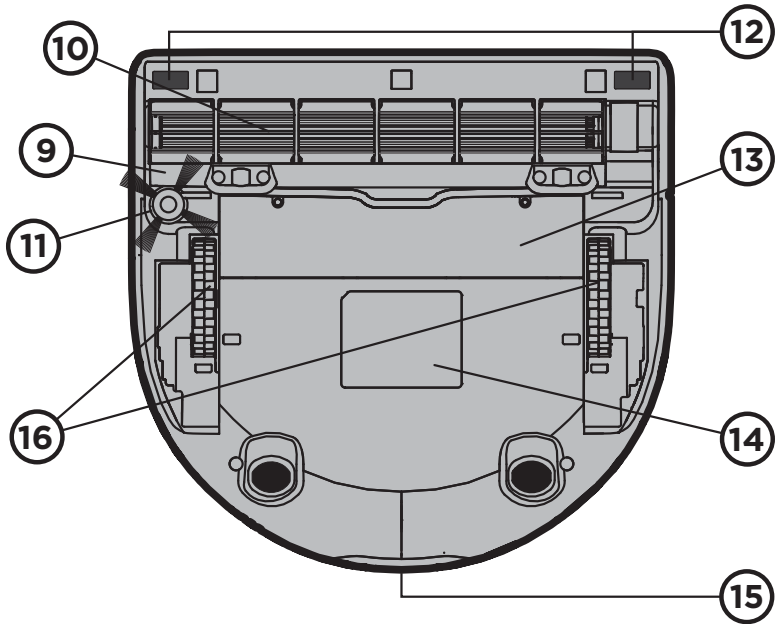

BACK VIEW

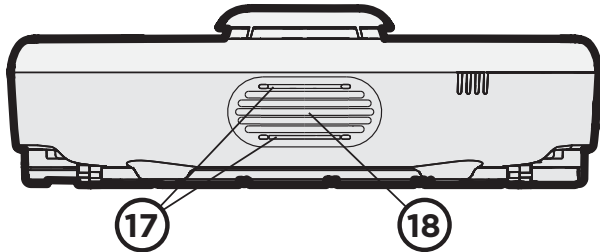

- 9** Brush Guard
- 10** Brush
- 11** Side Brush
- 12** Drop Sensor Windows
- 13** Battery Cover
- 14** Label (includes Serial Number)
- 15** Charging Contacts
- 16** Wheels
- 17** Charging Contacts
- 18** Blower Vents

CHARGE BASE

FRONT VIEW

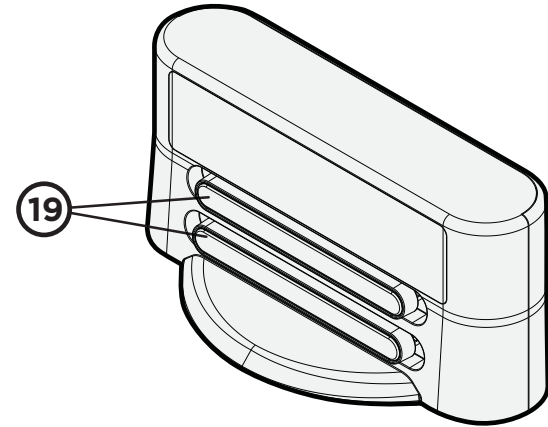

BACK VIEW

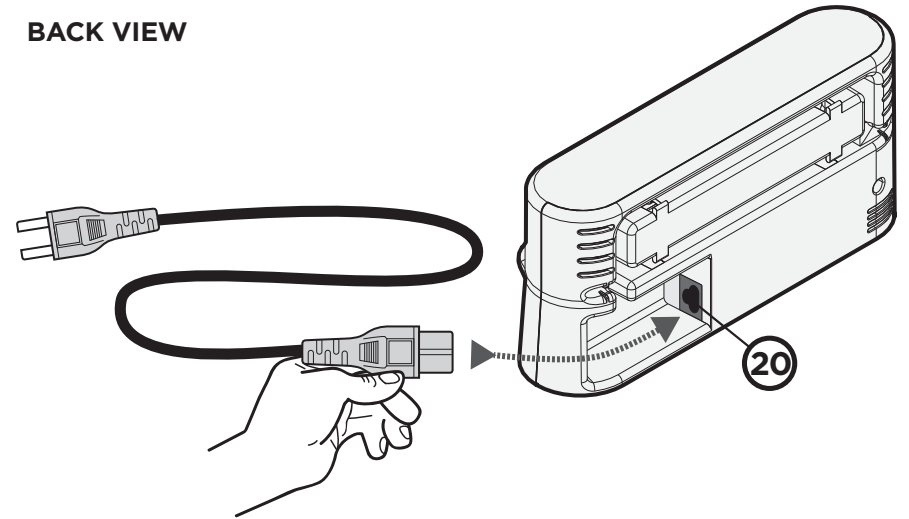

- 19** Metal Charge Plates (2)
- 20** Insert power cord securely into the charge base

3

CONTROLS

DISPLAY CONTROLS

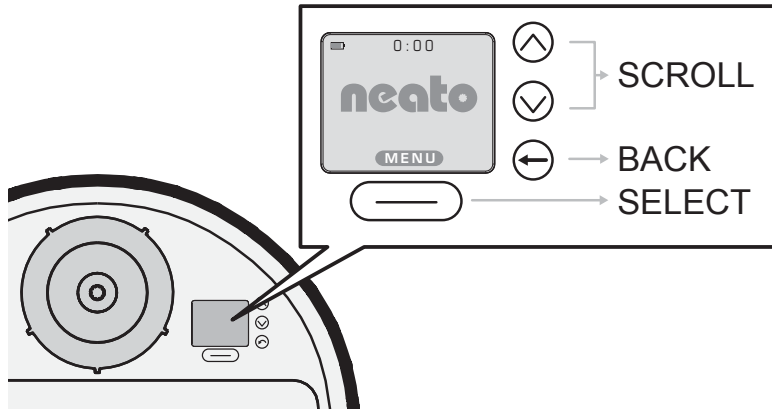

BUTTONS

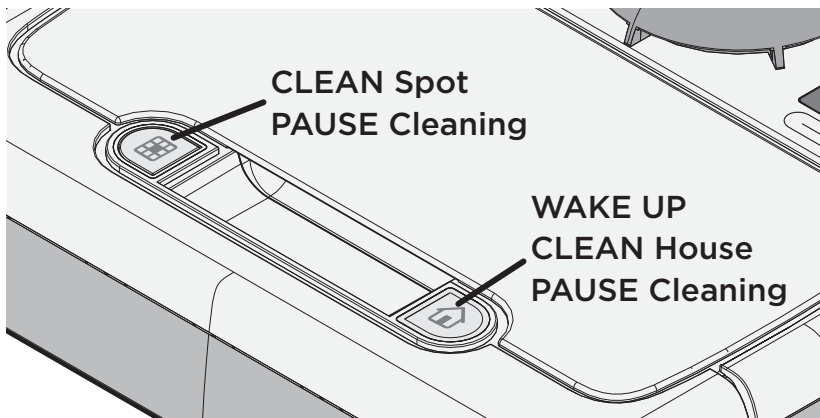

STATUS LIGHTS

The LED around the right button is used to indicate:

- Battery State
- Error Conditions - see display for description of error or alert

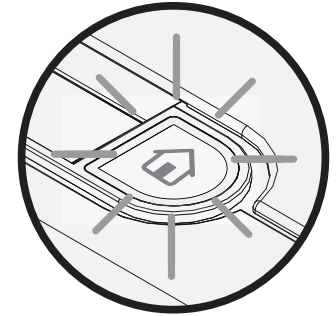
Status Lights**SOLID GREEN**

Fully charged and ready to clean.

BLINKING GREEN

Charging, battery not fully charged, can clean.

BLINKING AMBER

Charging, can't clean yet.

SOLID AMBER

Error, see message on screen.

4

SET LANGUAGE

Press **SELECT** button under the screen to go to **Main Menu**.

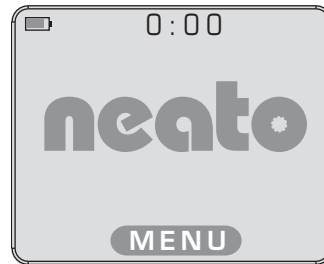

Use **SCROLL** button to scroll down to **Language** and then press **SELECT** button.

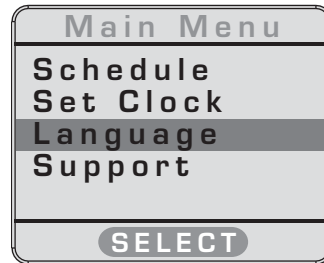

Find your language by using **SCROLL** button to scroll down.



Press **SELECT** button under the screen to choose a language.

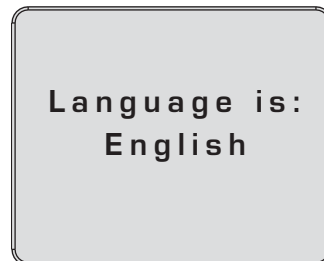

5

SET CLOCK

Press **SELECT** button under the screen to go to **Main Menu**.



Use **SCROLL** button to scroll down to **Set Clock** and then press **SELECT** button.

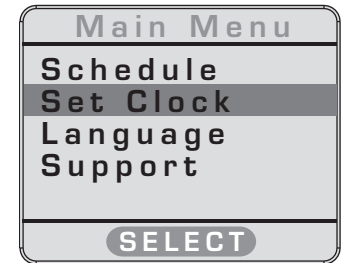

Use **SCROLL** button to Choose **12-Hour** or **24-Hour** Clock Mode and then press **SELECT** button.

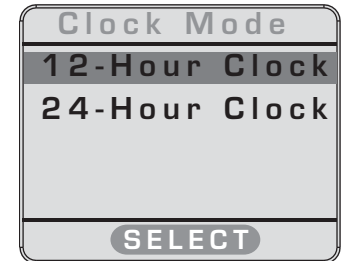

Use **SCROLL** button to choose **Day** and then press **SELECT** button.

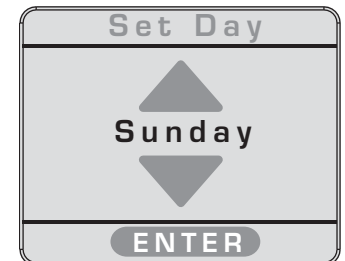

CLEANING

Use **SCROLL** button to **Set Hour** and then press **SELECT** button.



Use **SCROLL** button to **Set Minutes** and then press **SELECT** button.



If the time is correct press **SELECT** button to save the time.

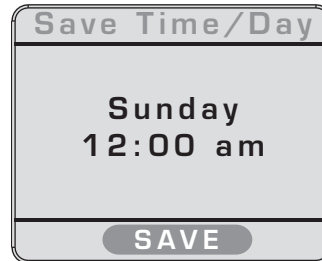

Confirmation message will show on the screen.

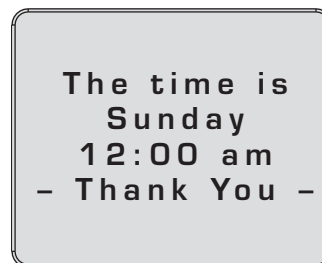

Botvac has two cleaning modes – **CLEAN House** and **CLEAN Spot**.

- **CLEAN House** mode will clean your house.
- **Clean Spot** mode will clean a 4' (1.2 m) x 6' (1.8 m) area.

IMPORTANT! To start cleaning, the LED around the right button must be green or blinking green and Botvac must be turned on.

- If the right button is not green or blinking green, put Botvac up against the charge base to charge.
- If the screen is not lit, press the right button  to wake up Botvac.

CLEAN HOUSE  MODE

Press the right button below the dirt bin with the  icon.

The screen will indicate that Botvac is cleaning the house.

Botvac will come off its charge base and scan the area.



If the area is less than about 15' (4.5 m) x 15' (4.5 m) it will do a boundary cleaning of the area and then clean the interior using a back and forth straight-line pattern.

If the area is larger than 15' (4.5 m) x 15' (4.5 m), it will create a virtual room that is about 15' (4.5 m) x 15' (4.5 m) and do a boundary cleaning and then clean the interior of the virtual room using a back and forth straight-line pattern. It will move on to vacuum the next virtual room. Depending on the size and configuration of the room, it may or may not finish one room before moving to the next. It will continue to clean in “segments” until the job is finished, keeping track of where it has and has not cleaned, using its sophisticated SLAM technology.

STARTING AT THE CHARGE BASE:

If Botvac started at the charge base and needs to recharge before finishing the job, it will navigate back to the charge base, wiggle up to it and recharge. You will see a message on the LCD that says “Cleaning Suspended While Charging”. It is in suspended cleaning mode while charging.



Once it recharges Botvac will go back out and resume cleaning where it left off. Botvac will do a maximum of three cleaning runs and two recharges between the cleaning runs. After the third cleaning run it will dock at its charge base and recharge.

STARTING OFF THE CHARGE BASE: If Botvac is not started at the charge base and cannot complete cleaning the area in one battery charge, it will go back to where it started and ask you to return it to the charge base to recharge.

It is in suspended cleaning mode while charging. When finished charging, place it within two feet of where it returned for charging, press START again, and it will return to where it left off to finish the cleaning job. It will repeat this one more time if it hasn't finished the cleaning job.

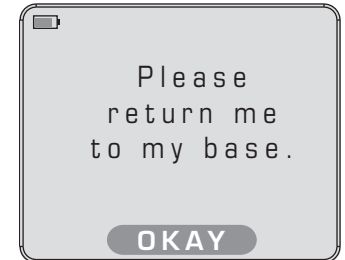

CLEAN SPOT MODE

Spot mode is used to clean a small area. Spot mode will clean a 4' (1.2 m) x 6' (1.8 m) area in front of Botvac.

To start Spot mode, put Botvac on the floor facing the area you want cleaned. Press the left button - with the  icon. The screen will show Botvac is CLEANING Spot.



Botvac will scan the area, turn right and do a boundary cleaning of a 4' (1.2 m) x 6' (1.8 m) area.

It will then clean the interior using a back and forth straight-line pattern and return to its starting location or if it saw a charge base while cleaning it will return to the charge base and wiggle up to it.

Tip! To put your Botvac to sleep, press and hold the **START** button for 2 seconds and the light on the screen will go off

Tip! Clear the area of small items like toys and clothing – furniture is OK.

IMPORTANT! Tie up wires, curtains and other low-hanging items.

IMPORTANT! Keep your Botvac away from liquids and wet areas. Move or cover pet bowls and plant trays.

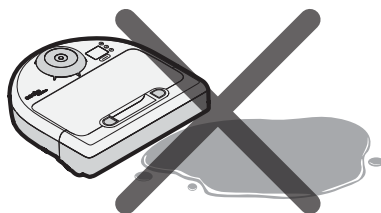

Tip! To keep your Botvac out of places you don't want it to go, set down boundary markers included in the package. Sometimes it's helpful to tape them down to hold them in place. See section on Boundary Markers for more information.

IMPORTANT! Keep your Botvac inside the house. It was not designed for outdoor cleaning or freezing temperatures.

TIP! Be aware that shiny surfaces and black floors may confuse your Botvac.

BOUNDARY MARKERS

7

Boundary markers let you create a boundary where one does not exist. They let you tell your Botvac where not to go.

Some examples of where to use boundary markers:

1. If you have a large open floor plan in your house, for example the room layout below, and you don't want the robot to clean the shaded area, you can use boundary markers.

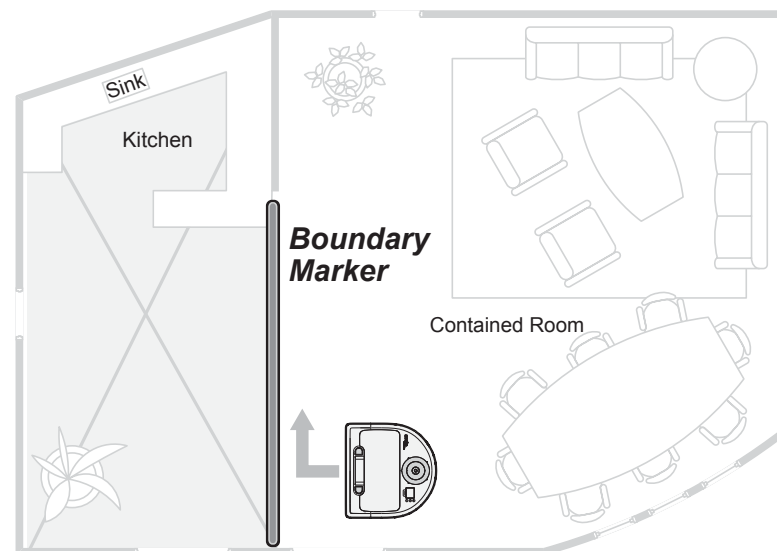

- Lay the boundary marker flat on the floor from one wall to the opposite wall to block off the area.
- Botvac will clean the floor on the side of the boundary marker that it starts on. It will recognize the boundary marker and will not cross it.

- If you have an item you don't want the robot to get near, for example electric cords, pet bowls or toys, place boundary markers around the item or area.

IMPORTANT! Thick carpeting on stairs may affect the robot's navigation system (stairs with thin carpeting are OK). To make sure your robot sees the stairs place boundary markers 6 inches from the edge of the stairs.

TIP! You can use scissors to cut boundary markers to a shorter length.

TIP! You can use removable tape such as gaffer tape or painters' tape to keep boundary markers flat on the floor.

SCHEDULING

8

You can schedule Botvac to clean your house once every day.

To make sure Botvac cleans your whole house keep it on its charge base. If its battery runs low it will come back to the charge base, recharge and resume cleaning where it left off (up to two times).

To schedule a **HOUSE** cleaning press **SELECT** button under the screen to go to **Main Menu**.



Press **SELECT** button under the screen to go to select **Schedule**.

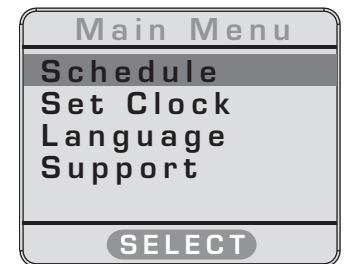

The **Schedule Menu** allows you to **Set** a new scheduled cleaning or **Change** a scheduled cleaning. You can schedule **HOUSE** cleanings once a day and you can schedule a different time for each day of the week if you want to.

The **Schedule Menu** also allows you to remove the schedule for a day (**Remove Day**) or **Turn Off** all scheduled cleanings.

Below is the sequence of actions and screens to schedule a House cleaning on **Saturday at 12:00 am**.

Press the **SELECT** button below.

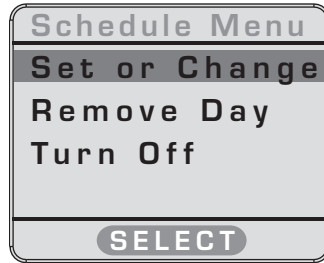

Use the **SCROLL** buttons to scroll down to **Saturday** Press the button below **SELECT**.

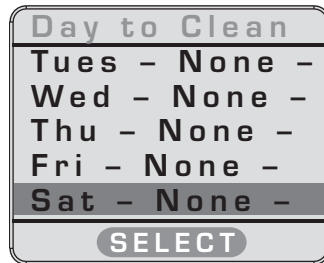

Press the **SELECT** button to select the hour. Advance the hour so you choose am/pm correctly.



Press the **SELECT** button to select the minute.



Press the **SELECT** button to confirm the scheduled cleaning.

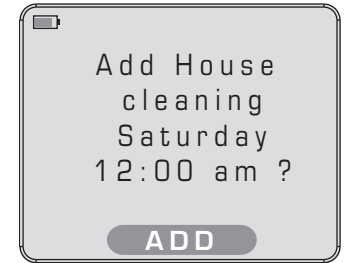

Screen confirming scheduled cleaning.

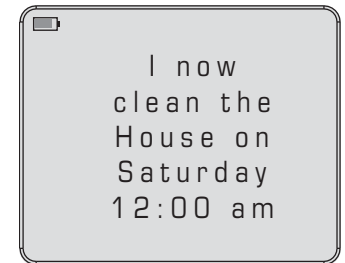

Tip! If your battery runs very low, the Botvac will lose its clock setting. Use the menus to reset the time and day

9

MAINTENANCE

IMPORTANT! Keeping Botvac clean is important for optimum performance.

CLEANING THE FILTER

For optimal performance, empty the Botvac dirt bin and clean the filter after every use.

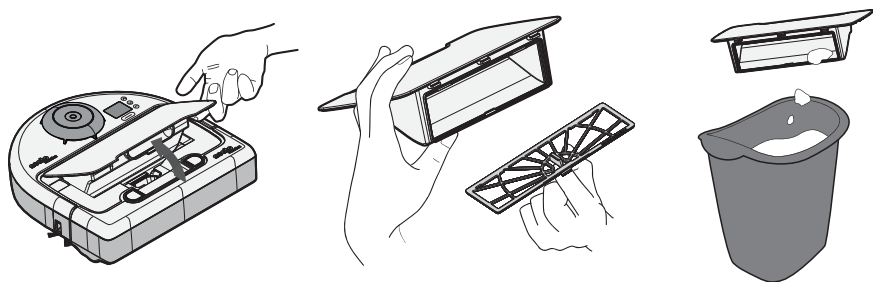

1. Take out the dirt bin.
2. Remove the filter.
3. Empty the contents of the dirt bin into a garbage can. Tap the filter against the garbage can to get rid of any excess dirt.
4. Replace the filter and make sure it is tight. Insert the dirt bin back into the Botvac and make sure it is fully engaged.

Tip! Change the filter in your Botvac every one to two months. Factors that determine how often to change the filter include: frequency of vacuuming, size of the area it is cleaning, and the amount of dirt, debris and pet hair it picks up.

Tip! Go to www.neatorobotics.com and click on **Where To Buy** to find retailers where you can purchase Genuine Neato Accessories.

CLEANING THE BRUSH AND BEARING

Clean the brush frequently. Most hair and other debris are captured in the dirt bin, but some may get tangled on the brush and affect cleaning performance. To clean the brush, follow these steps:

1. Turn your Botvac upside down.
2. Place your fingers under the brush guard in front of the wheels and pull up gently under the brush guard until it pops out. Remove the brush guard.
3. Gently take out the brush.
4. Remove any debris from the brush. Wipe the brush blades and brush core with a slightly damp cloth to remove dust.
5. Remove the metal bearing on the end of the brush and clean with a cloth. To remove the bearing, use your fingers, or a small flat head screwdriver for tough to remove the bearing. Re-attach the bearings to the brush.
6. Replace the brush by inserting the orange end cap with the hexagon pattern into the motor-side, and the metal bearing end closest to the wall side.
7. Replace the brush guard, and click it into place. Make sure it is seated correctly in front behind the bumper and locked tightly at the rear.

For optimal performance, replace the brush periodically, or if the blades or bristles are damaged. You can find replacement brushes through one of our partners. Go to www.neatorobotics.com and click on the **Where to Buy**.

CLEANING THE DROP SENSORS

Using a cotton swab, periodically clean the drop sensor windows (2) on the bottom of your Botvac (see below).

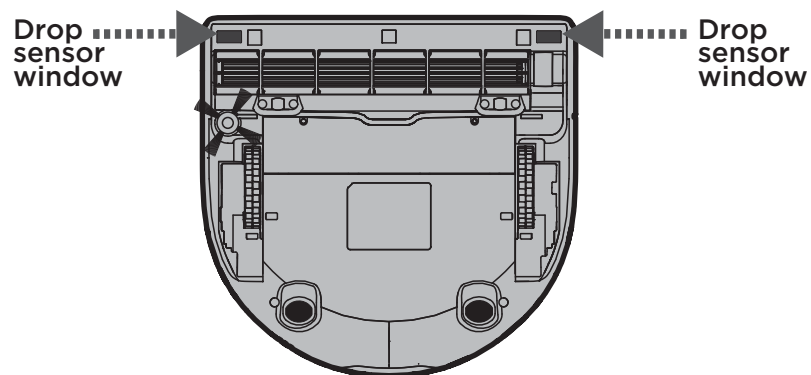

CLEANING THE TOP OF YOUR BOTVAC

Clean the top of your Botvac periodically with a damp cloth.

Make sure there is no dirt accumulated under the Laser Cover. If there is any dirt or debris, remove it so the laser can navigate your home accurately.

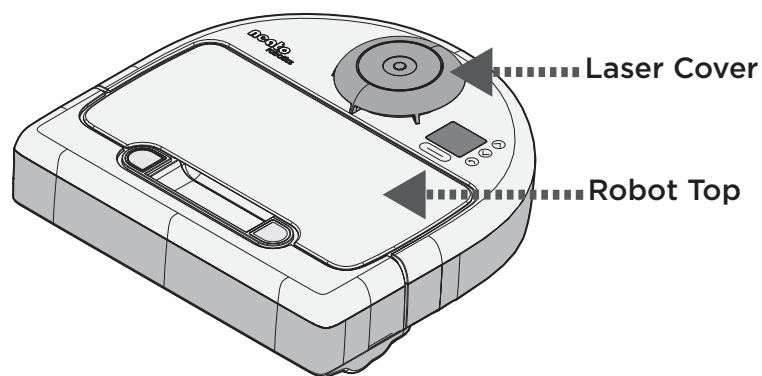

WHERE TO BUY NEATO BOTVAC™ GENUINE ACCESSORIES

Go to www.neatorobotics.com and click on **Where to Buy** to find replacement accessories and parts for your Botvac.

Combo Brush	Length = 10.875 in / 276 mm Best brush for picking up pet hair. Much quieter on hard floors.	
Blade Brush	Length = 10.875 in / 276 mm Superior cleaning performance for all floor types.	
Side Brush	For precise edge cleaning.	
Standard Filter	Surface area = 13.1 in ² / 85 cm ²	
High-Performance Filter	Surface area = 84.7 in ² / 547 cm ² Captures particles down to 0.3 microns - more than three times the amount of fine dust particles as a standard filter.	
Dirt Bin	Size: 0.7 liters Bigger-is-better dirt bin holds more and is easy to empty.	
Boundary Markers	Magnetic strips keep your Botvac where you want it to go.	
Battery	Rechargeable NiMH 12V 3600 mAh battery.	
Charge Base	Extra charge base is great for homes with stairs.	

10

BATTERIES AND
CHARGE BASE

BATTERY SWITCH

Botvac is shipped from the factory with the battery switch in the OFF position to extend battery life.

To connect the battery, open the dirt bin and push the **ON/OFF** switch **DOWN** to **ON**.

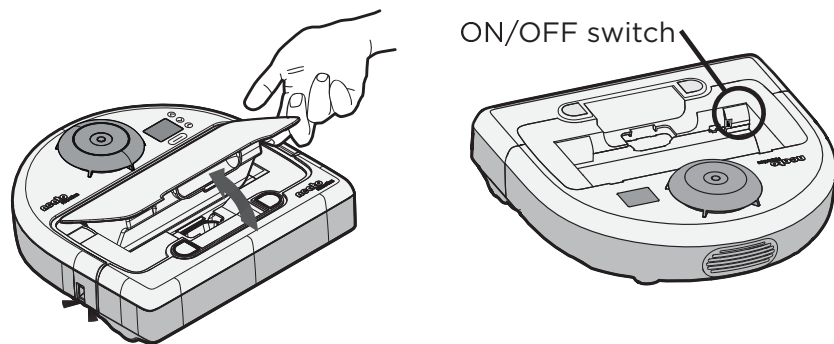

ON/OFF Switch:

- You push the **ON/OFF** switch **UP** to turn **OFF** the robot.
- You push the **ON/OFF** switch **DOWN** to turn **ON** the robot.

Tip! If you will not be using Botvac for an extended period of time, you can extend the life of the battery by pushing the battery switch in the dirt bin **UP** to **OFF**.

CHARGE BASE LOCATION

Choose a wall outlet that has a 3' (1 m) clearance on both sides and in front of the charge base. This helps your Botvac find its charge base.

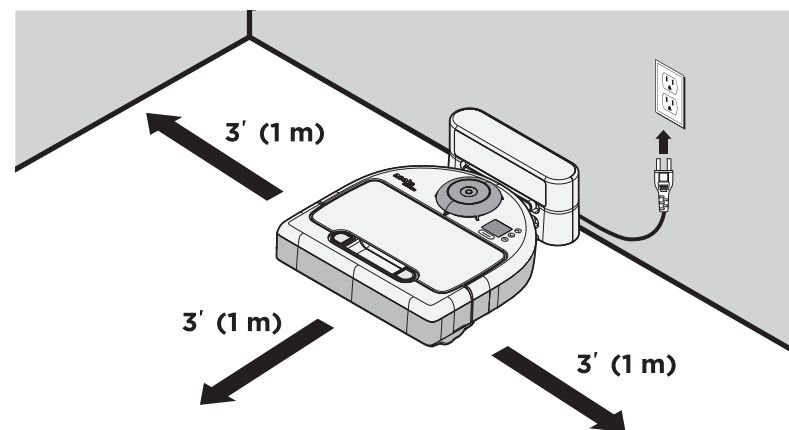

BATTERY CHARGE TIME

Botvac takes two to three hours to charge fully. The status light turns solid green when the batteries are completely charged. Several factors influence charging time.

- **The charge level of the battery:** If the battery is almost drained, charging will take closer to three hours. If partially charged, it will take less time to reach full capacity.
- **The environment of the room:** It will charge faster on a hard surface located in a cool dry area. On hot days, on carpet, expect longer charging times.

We recommend you charge the batteries overnight before you use Botvac for the first time. Run through three complete charging cycles to optimize the performance of the batteries.

BATTERY CALIBRATION

You can re-calibrate Botvac's batteries to improve capacity and lengthen run time between charges. You should recalibrate the batteries in these situations:

- Botvac is new
- The batteries are new
- You updated the software
- Your cleaning area expanded
- Botvac's run time is low

Follow the steps below to recalibrate Botvac's battery.

1. Turn off any scheduled cleaning.
2. Reset the batteries by going to MENU->Support->New Batteries.
3. Place it on its charge base overnight to ensure a full charge.
4. Run it until it finishes cleaning the maximum area you ever want it to clean, or until it displays "Battery Low" on its display and needs to recharge.
5. Dock it on its charge base for a full charge, until the status light turns solid green.
6. Run it as usual until it needs to recharge again.
7. Repeat step 6 two more times.

IMPROVING BATTERY LIFE

By following a few simple rules, you can help extend the life of your battery. How you take care of the battery – and how much you use them – affect their longevity. Here are some tips to optimize your battery.

- **Keep Botvac on its charge base when not in use – out of sunlight and heat, and on a flat surface.** Make sure the charge base is located in a cool, dry place, away from direct sunlight or other sources of heat like a heating vent. Keep the charge base on a smooth, hard surface. Thick carpets can cause the charge base to tilt, which prohibits it from making proper contact with the base.
- **Store Botvac with the batteries disconnected, or turned OFF.** If you are going away and won't use it for an extended time, charge the batteries fully and then disconnect them for storage by pushing the battery switch in the dirt bin **UP** to **OFF**. When you want to use your Botvac again, reconnect the batteries by pushing the battery switch **DOWN** to **ON** and fully charge it.
- **Charge as soon as possible after discharging the batteries.** If the battery is low and the LED is amber or blinking amber, charge the batteries as soon as possible.
- **Keep Botvac's filters and brushes clean.** If the filter or brush gets clogged with hair or other debris, the vacuum will strain, using more battery power than normal. Be sure to clean your filters and brushes regularly.
- If you are running into any issues with charging, run times or other battery related concerns please see section on Battery Calibration.

BATTERY REPLACEMENT

Because rechargeable batteries have a limited life span, you will need to replace the batteries periodically. How long the batteries last depends how you use your Botvac. You may have to replace your battery after 6 months if the runtime degrades. Every time the battery goes through a charge and discharge cycle it loses some capacity.

Higher temperatures also affect battery life. It is recommended you try to place your Botvac in a cool, shaded part of your home to reduce heat.

Replacement batteries for your Botvac can be found at one of our partner's websites. Go to www.neatorobotics.com and click on **Where to Buy**.

TROUBLESHOOTING

11

ALERTS:

Alert messages inform you of Botvac's condition but should not affect its ability to clean. These screens are temporary and can be turned off by pressing "OKAY".

What the screen says	What it means	What to do
<p>A Software update is available. Please visit web support.</p> <p>OKAY</p>	The software on your robot needs to be updated	If issue persists, please contact Neato Customer Care. Go to neatorobotics.com and click on Support for additional information.
<p>Please open my dirt bin & push switch DOWN to ON.</p> <p>OKAY</p>	The battery switch is set to OFF, the battery is not charging and the robot cannot run.	Open the dirt bin and push the battery switch DOWN to ON . Place the dirt bin back into robot and press OKAY to continue using. Make sure robot is fully charged before cleaning. Be sure to charge overnight the first time you charge the robot.
<p>0:00</p> <p>CLEANING SUSPENDED WHILE CHARGING</p> <p>PAUSE</p>	The robot needs to return to the charge base to recharge. When the robot is done charging it will return to where it left off to finish cleaning.	Let the robot return to the charge base to recharge. If it is already on the charge base, leave the robot on the charge base while it recharges.

ERRORS:

Error messages require your attention before Botvac can proceed. The LEDs will change to red to notify you that there is an error. The error message will display until you correct the error condition, and/or press the OKAY button to clear.

What the screen says	What it means	What to do
<p>Please press OKAY to continue. Battery issue (8000)</p> <p>OKAY</p>	The battery is experiencing an error.	<p>If issue persists, contact Neato Customer Care.</p> <p>Go to neatorobotics.com and click on Support for additional information.</p>
<p>Please press OKAY to continue. Battery issue (0003)</p> <p>OKAY</p>	The battery is low or needs to be charged.	<p>Press OKAY</p> <p>Put the robot on the charge base until the status light turns green.</p> <p>If issue persists, please contact Neato Customer Care. Go to neatorobotics.com and click on Support for additional information.</p>
<p>Please press OKAY to continue. Battery issue (0004)</p> <p>OKAY</p>		

<p>Please press OKAY to continue. Battery issue (0005)</p> <p>OKAY</p>	There is an issue with the battery.	If issue persists, please contact Neato Customer Care. Go to neatorobotics.com and click on Support for additional information.
<p>Please press OKAY to continue. Battery issue (0006)</p> <p>OKAY</p>		
<p>Please press OKAY to continue. Battery issue (0007)</p> <p>OKAY</p>	The robot is too cold or in an environment that is too cold for it to operate properly.	Charge the robot in a warmer environment.
<p>Please wait while I cool down my battery.</p> <p>OKAY</p>	<p>The battery is overheated.</p> <p>This may be caused by being in direct sunlight or in an unusually warm environment.</p>	<p>Allow your robot to cool down before attempting to run again. Try placing the robot in a cool, shaded area.</p> <p>If issue persists, please contact Neato Customer Care. Go to neatorobotics.com and click on Support for additional information.</p>

<p>Please press OKAY to continue. Battery issue (0002)</p>	<p>The battery is not properly connected.</p>	<p>Press OKAY Open the dirt bin and make sure the ON/OFF switch on the left in the dirt bin is DOWN. Replace the dirt bin.</p>
<p>Please press OKAY to continue. Battery issue (0008)</p>		<p>If issue persists, please contact Neato Customer Care. Go to neatorobotics.com and click on Support for additional information.</p>
<p>Please press OKAY to continue. Battery issue (0009)</p>		
<p>I had to reset Please press OKAY to restart.</p>		<p>An error occurred.</p>

<p>My fan is stuck. Please press OKAY to restart.</p>	<p>The blower is not working properly.</p>	<p>Make sure you have a filter installed, that the blower fan intake isn't blocked, and that the exhaust vent in the back of the robot isn't clogged.</p>
<p>Please contact Customer Support. Tests not complete.</p>		<p>Botvac needs to be inspected for errors.</p>
<p>My Brush needs to be cleaned.</p>	<p>The brush is still moving but with difficulties due to accumulated debris.</p>	<p>Make sure the brush or bearing does not have debris wrapped around it. Follow the brush and bearing cleaning instructions.</p>
<p>Please clean my Brush.</p>	<p>The brush is stuck with debris.</p>	<p>Make sure the brush and bearing do not have debris wrapped around it. Follow the brush and bearing cleaning guide.</p>

<p>Please wait while I check my surrounding.</p>	<p>Botvac is trying to locate itself in the environment.</p>	<p>Give the robot a moment to orient itself in the room. Note: If you pick up the robot and move it in the room it may become disoriented. Avoid picking up the robot during a cleaning cycle. If this is a recurring issue try moving objects around to give the robot better reference points to use for navigating.</p>
<p>Please Dust me off so that I can see.</p> <p>OKAY</p>	<p>The robot cannot sense the environment because the laser is blocked.</p>	<p>Make sure the protective screen film has been fully removed and is not peeling up and blocking the robot's vision. Use a clean cloth to pick up any dirt or dust on or around the turret.</p>
<p>Please empty my Dirt Bin and Filter if needed.</p>	<p>The dirt bin and the filter may be full of dust or debris.</p>	<p>Empty the dirt bin and make sure filter is clear of debris. Put dirt bin and filter back into the robot.</p>

<p>I can't shut down while I am connected to power.</p> <p>OKAY</p>	<p>The robot cannot shutdown while it is connected to the charge base.</p>	<p>Remove your robot from the charge base before attempting to shutdown.</p>
<p>Please check my filter and Dirt Bin.</p> <p>OKAY</p>	<p>There is a problem with the filter or dirt bin.</p>	<p>Make sure the dirt bin is empty, that the filter is in place and not obstructed, and that the dirt bin is properly inserted.</p>
<p>Please put my Dirt Bin back in.</p> <p>OKAY</p>	<p>The dirt bin cannot be detected.</p>	<p>Make sure the dirt bin is in the robot and properly seated in position. The top of the dirt bin should be level with the top of the robot if inserted correctly.</p>
<p>My Right Wheel is stuck. Please free it from debris.</p> <p>OKAY</p>	<p>The right wheel is stuck and the robot is experiencing mobility problems.</p>	<p>Make sure the wheel does not have debris wrapped around it. If issue persists, please contact Neato Customer Care. Go to neatorobotics.com and click on Support for additional information.</p>

<p>My Left Wheel is stuck. Please free it from debris.</p> <p>OKAY</p>	<p>The left wheel is stuck and the robot is experiencing mobility problems.</p>	<p>Make sure the wheel does not have debris wrapped around it.</p> <p>If issue persists, please contact Neato Customer Care. Go to neatorobotics.com and click on Support for additional information.</p>
<p>Please put me down on the floor.</p> <p>OKAY</p>	<p>Botvac was picked up. It must be returned to the floor to resume operation.</p>	<p>Place the robot back on the floor.</p>
<p>Please clean my right drop sensor window.</p> <p>OKAY</p>	<p>The right drop sensor window on the under side of Botvac needs to be cleaned.</p>	<p>Gently clean the drop sensors with a soft cloth</p>
<p>Please clean my left drop sensor window.</p> <p>OKAY</p>	<p>The left drop sensor window on the under side of Botvac needs to be cleaned.</p>	<p>Gently clean the drop sensors with a soft cloth</p>

<p>My Bumper is stuck. Please free it.</p> <p>OKAY</p>	<p>The bumper or bumper sensor are being triggered and may be stuck.</p>	<p>Gently tap the bumper to free it — you should hear TWO clicks when the bumper is pressed. One when it is pressed in and one when it pops back out.</p>
<p>Please return me to my base.</p> <p>OKAY</p>	<p>Botvac needs to recharge and cannot find a charge base.</p>	<p>If the cleaning session was started from a charge base:</p> <ol style="list-style-type: none"> 1. End current cleaning cycle. 2. Relocate the charge base to a more open area with at least 3 feet of open space on either side of it so the robot can better locate the charge base when it needs to return for recharging. 3. Take the robot to the charge base and restart the cleaning cycle. <p>If a cleaning was started away from a charge base (example - for spot cleaning or to clean another room without a charge base) then the robot will return to where it started. Pick up the robot and place it on the charge base.</p>

<p>My battery is low. I need to charge my battery before I can clean.</p>	<p>The battery is low and cannot clean until the battery is charged.</p>	<p>Allow the robot to finish charging on the charge base.</p>
<p>Please check that the base is connected to power.</p>	<p>Botvac docked to the charge base but can't charge.</p>	<p>Ensure the charge base is connected to a functioning electrical socket on the wall and located on a flat surface.</p>
<p>Please set schedule to ON first.</p>	<p>You must turn on the scheduling feature before you can set or change the schedule.</p>	<p>Make sure scheduling is turned on by going to MENU > Schedule > Turn On.</p>
<p>I can't charge. Try moving the base station to a new location.</p>	<p>Botvac is having difficulty getting to or locating the charge base and cannot recharge.</p>	<p>Move the charge base to another location in an open area with 3 feet on either side. Push robot up to charge base to recharge.</p>
<p>OKAY</p>		<p>If issue persists, please contact Neato Customer Care. Go to neatorobotics.com and click on Support for additional information.</p>

<p>Please clear my path. (2000)</p>	<p>Botvac is having difficulty navigating the environment.</p>	<p>Follow these steps to troubleshoot:</p>
<p>OKAY</p>	<p>Some reasons this occurs:</p> <ul style="list-style-type: none"> • The laser is blocked. • It is having difficulty navigating the floor. • The sensors are dirty or not working properly. • The wheels or brush are dirty. 	<ol style="list-style-type: none"> 1. Make sure there is nothing preventing the robot from moving forward (e.g., obstacles, tangled in cords, robot is not flat on floor)
		<ol style="list-style-type: none"> 2. Make sure nothing in the environment has changed since the robot started cleaning (e.g., furniture moved, robot moved to different room)
		<ol style="list-style-type: none"> 3. Make sure the screen sticker that came with the robot has been completely removed.
		<ol style="list-style-type: none"> 4. The robot needs to be reset. Push the battery switch UP to OFF, wait 5 minutes and push DOWN to turn back ON.
		<ol style="list-style-type: none"> 5. Make sure wheel wells aren't blocked with debris.
		<ol style="list-style-type: none"> 6. Make sure the battery is charged <p>If issue persists, please contact Neato Customer Care. Go to neatorobotics.com and click on Support for additional information.</p>

12 NEATO CUSTOMER CARE & PRODUCT REGISTRATION

Visit www.neatorobotics.com and click on the **Support**.

Register your Neato Botvac to stay up to date on software releases and new product information.

Find more helpful information, including frequently asked questions, and tips and tricks for optimal operation.



neato™

www.neatorobotics.com

Neato Robotics, Inc.
8100 Jarvis Avenue,
Newark, CA 94560 USA